



# PZH Series High Pressure Piston Pump



PZH-4B



PZH-3B



PZH-2B



PZH-1B



PZH-0B

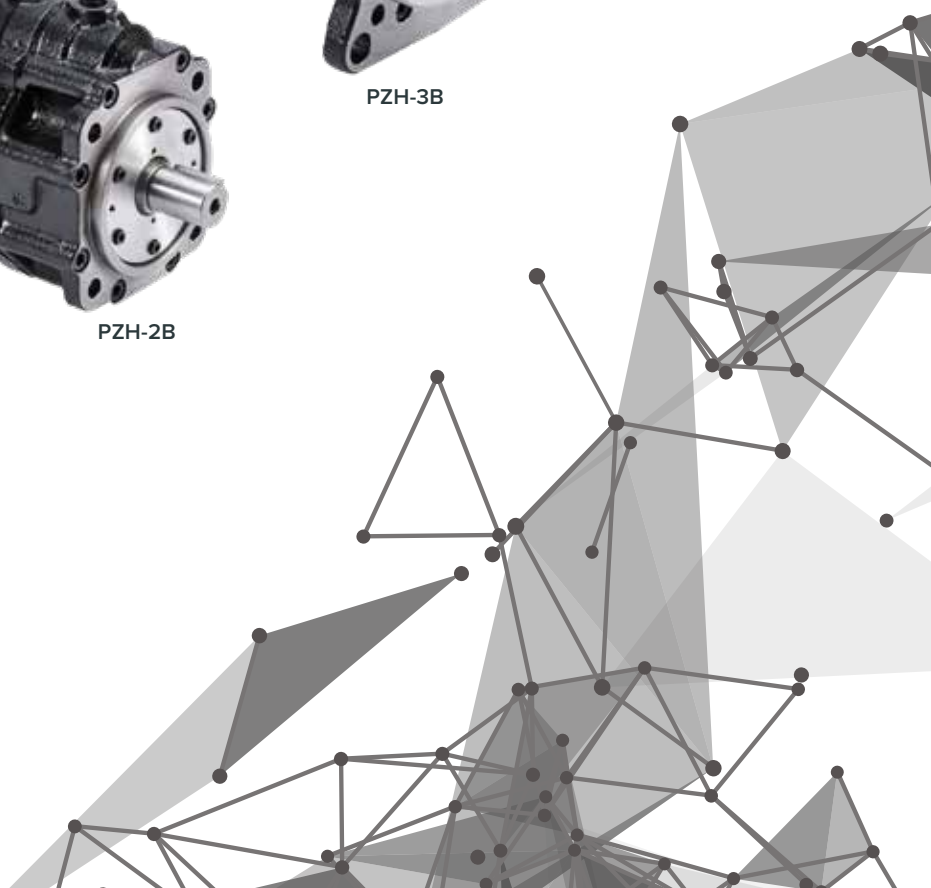

# Features

- Max operating pressure 5000 psi
- Low noise level: Full cut-off at 5000 psi
- Long Lifetime with high load resistant Nachi Bearings
- Several variable control mechanisms available
- Strong structure for high durability



PZH-3B

## Explanation of Model Number

PZH - \* B - \* N 5 - 10

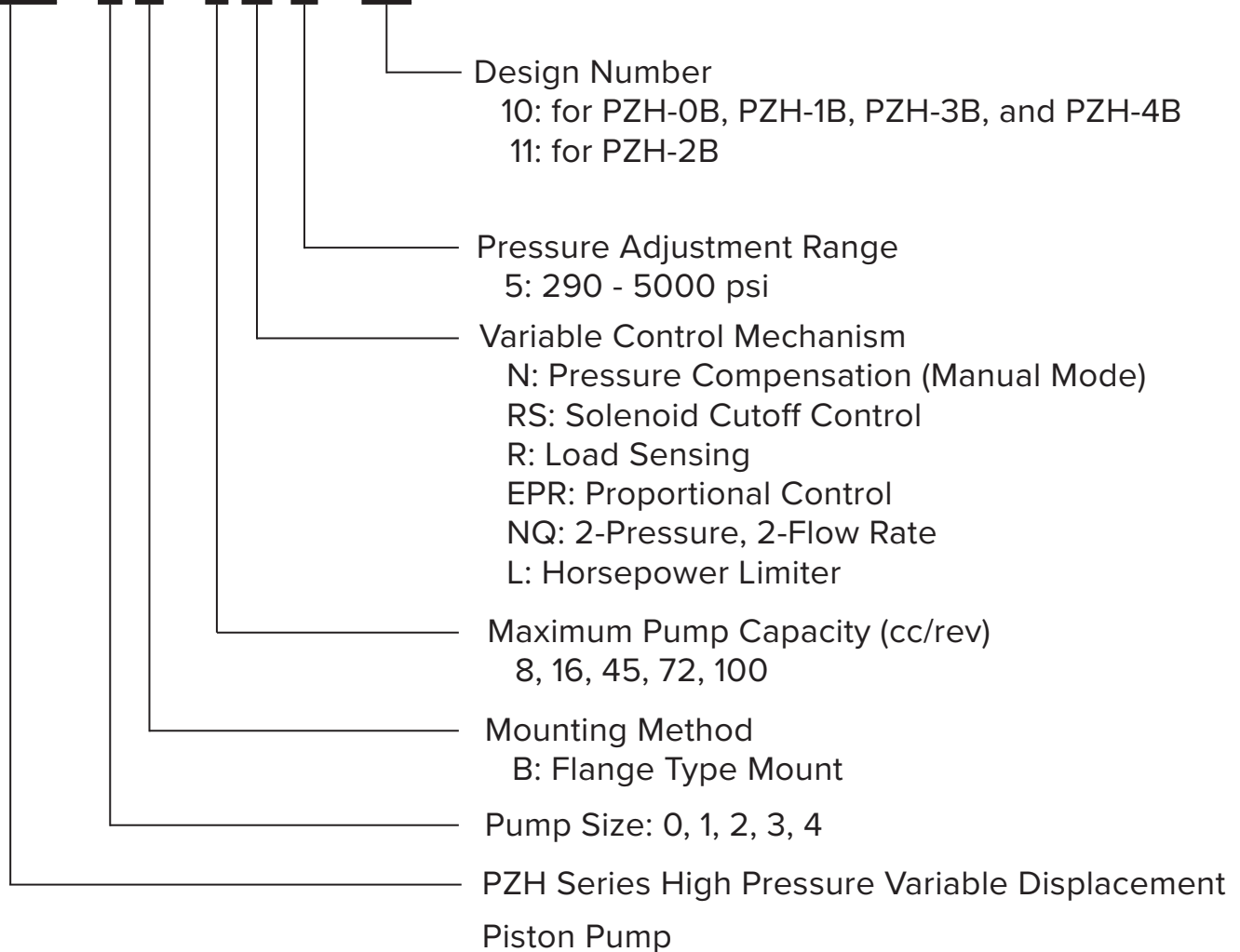



PZH-1B



PZH-0B



PZH-2B

## Applications

- Forging Machine
- Injection Molding Machine
- Test Bench

## Pressure & Pump Capacity

Rate Pressure: 5000 psi

Peak Pressure: 5800 psi

Pump Capacity: 0.49 in<sup>3</sup>/rev, 1.00 in<sup>3</sup>/rev, 2.74 in<sup>3</sup>/rev, 4.39 in<sup>3</sup>/rev, & 6.00 in<sup>3</sup>/rev

## Applications

Model No.	Pump Capacity in <sup>3</sup> rev (cc/rev)	Discharge at Volume No-Load (gpm)	Pressure Range(psi)	Allowable Peak Pressure (psi)	Rotating Speed (rpm)		Port Size	Flange Size	Mass (lbs)
		1800 rpm			Min	Max			
PZH-0B	PZH-0B	3.8	290 - 5000	5800	500	2000	Inlet: Code 61 3/4" Outlet: Code 62 1/2"	SAE-A 2 Bolt Flange	26
PZH-1B	PZH-1B	7.8					Inlet: Code 61 1" Outlet: Code 62 3/4"	SAE-B 2 Bolt Flange	35
PZH-2B	PZH-2B	21.4					Inlet: Code 61 1-1/2" Outlet: Code 62 1"	SAE-C 4 Bolt Flange	68
PZH-3B	PZH-3B	34.2					Inlet: Code 61 2" Outlet: Code 62 1-1/4"	SAE-D 4 Bolt Flange	95
PZH-4B	PZH-4B	47.6					Inlet: Code 61 2-1/2" Outlet: Code 62 1-1/2"	SAE-D 4 Bolt Flange	141

## Variable Control Mechanism

Pump Model	Pump Capacity (in <sup>3</sup> /rev)	Pressure Compensation (Manual)	Solenoid Cutoff Control	Load Sensing	Proportional Valve Control	2-Pressure 2-Flow rate	Horsepower Limiter
		N	RS	R	EPR	NQ	L
PZH-0B	0.49	✓	✓	✓	✓	X	X
PZH-1B	1.00	✓	✓	✓	✓	✓	X
PZH-2B	2.74	✓	✓	✓	✓	X	✓
PZH-3B	4.39	✓	✓	✓	✓	X	✓
PZH-4B	6.00	✓	✓	✓	✓	X	✓
P-Q Characteristic							

✓: Standard Model, X: Not Available

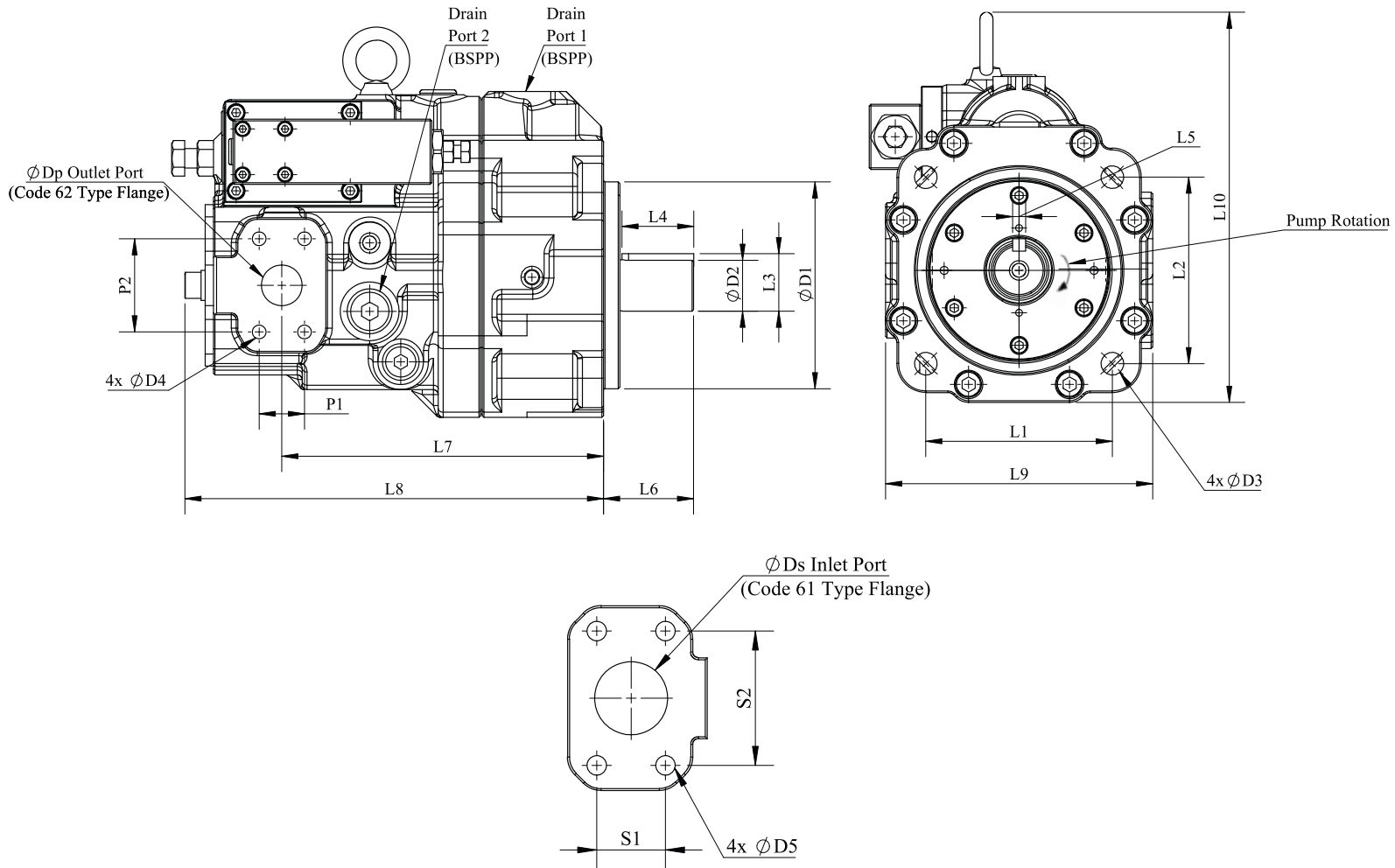

Pump Model	D1		D2		L1		L2		L3		L4		L5		L6		L7		L8	
	mm	in	mm	in	mm	in	mm	in	mm	in	mm	in	mm	in	mm	in	mm	in	mm	in
PZH-0B	82.6	3.25	19.1	0.75	106.4	4.19	-	-	21.2	0.83	25.4	1.00	4.8	0.19	43.0	1.70	144.5	5.69	167.5	6.60
PZH-1B	101.6	4.00	22.2	0.88	146.0	5.75	-	-	24.9	0.98	38.0	1.50	6.3	0.25	60.0	2.36	170.5	6.71	193.5	7.62
PZH-2B	127.0	5.00	31.8	1.25	114.5	4.51	114.5	4.51	35.3	1.39	44.0	1.73	7.9	0.31	55.0	2.17	194.0	7.64	256.5	10.10
PZH-3B	152.4	6.00	38.1	1.50	161.6	6.36	161.6	6.36	42.2	1.66	55.0	2.17	9.5	0.38	90.0	3.54	225.5	8.88	287	11.30
PZH-4B	152.4	6.00	44.45	1.75	161.6	6.36	161.6	6.36	49.43	1.95	88.0	3.46	11.13	0.44	96.0	3.78	260.0	10.24	326.5	12.85

Pump Model	L9		L10		P1		P2		Dp		D3	S1		S2		Ds		D4	D5	Drain Port
	mm	in	mm	in	mm	in	mm	in	mm	in		mm	in	mm	in	mm	in			
PZH-0B	120.0	4.72	157.0	6.18	18.2	0.72	40.5	1.59	13.0	0.51	M10	22.0	0.87	47.5	1.87	19.0	0.75	M8	M10	BSPP 3/8
PZH-1B	124.0	4.88	162.0	6.38	23.8	0.94	50.8	2.00	19.0	0.75	M10	26.2	1.03	52.4	2.06	24.0	0.94	M10	M10	BSPP 3/8
PZH-2B	170.0	6.69	239.5	9.43	27.8	1.09	57.2	2.25	25.0	0.98	M12	35.7	1.41	69.8	2.75	38.0	1.50	M12	M12	BSPP 1/2
PZH-3B	188.0	7.40	270.5	10.65	31.8	1.25	66.7	2.63	32.0	1.26	M20	42.9	1.69	77.8	3.06	48.0	1.89	M12	M12	BSPP 3/4
PZH-4B	215.0	8.46	294.5	11.59	36.5	1.44	79.4	3.13	38.0	1.50	M20	50.8	2.00	88.9	3.50	60.0	2.36	M14	M12	BSPP 3/4

**NACHI**  
NACHI AMERICA INC.

☎ 877.622.4487  
✉ ml-nai.hydraulics@nachi.com  
🌐 www.nachiamerica.com

📍 Nachi America Inc.  
715 Pushville Road  
Greenwood, IN 46143