

NACHI CERAMIC HYBRID BALL BEARINGS

SH6 - Deep Groove Ball Bearings

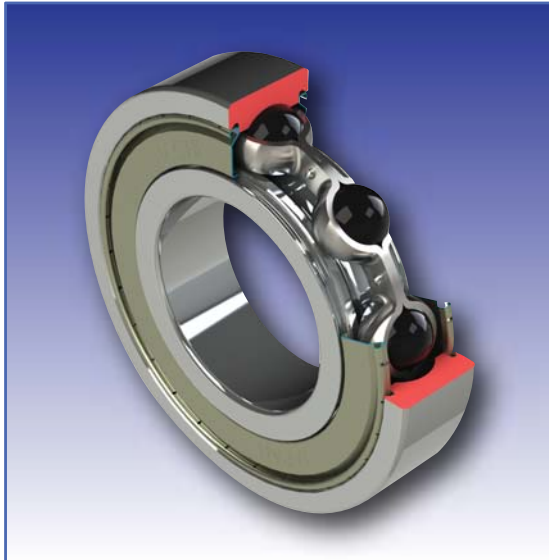

Advanced Features...

- Eliminates electric arcing or fluting by insulating the bearing
- Low temperature rise at high speeds
- Non-conductive
- Double shielded and filled with Exxon Polyrex® EM grease

Cost Saving Features...

- Dimensionally interchangeable with current electric motor bearing
- No special modifications required for installation

With Silicon Nitride rolling elements and SUJ2 (AISI 52100) Steel Bearing Rings

The use of ceramic rolling elements make these bearings ideally suited for a wide range of extreme applications where high temperatures, high speed or electric current threaten the life of traditional steel bearings.

- Electric Motor Industry
- Traction Motors
- Power Generation
- High Speed Industrial Machinery
 - Routers
 - Lathes
 - CNC Machinery and more!

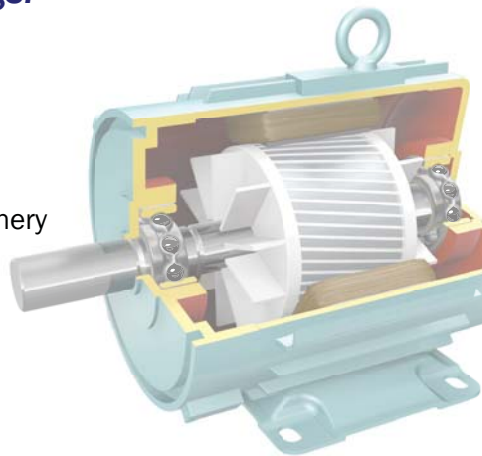

Model Numbers	
6200 Series	6300 Series
SH6-6203ZZEC3	
SH6-6204ZZEC3	
SH6-6205ZZEC3	SH6-6305ZZEC3
SH6-6206ZZEC3	SH6-6306ZZEC3
SH6-6207ZZEC3	SH6-6307ZZEC3
SH6-6208ZZEC3	SH6-6308ZZEC3
SH6-6209ZZEC3	SH6-6309ZZEC3
SH6-6210ZZEC3	SH6-6310ZZEC3
SH6-6211ZZEC3	SH6-6311ZZEC3
SH6-6212ZZEC3	SH6-6312ZZEC3
SH6-6213ZZEC3	SH6-6313ZZEC3
SH6-6214ZZEC3	SH6-6314ZZEC3
SH6-6215ZZEC3	SH6-6315ZZEC3
	SH6-6316ZZC3

For additional sizes and configurations, please consult NACHI.